

TechTip: Recommendation for PLC items with base and pluggable logic

Example: Siemens ET200SP with pluggable electronics (electronic module / BaseUnit)

In the configuration of PLC devices, such as the ET200SP series of SIEMENS, two parts are used:

1. The BaseUnit to which the cables and wires to sensors and actuators are connected,
2. The electronic module with the electronics for the PLC inputs and outputs.

The connection points of a BaseUnit can pass different signals / channels outwards depending on the respective electronics module. An electronic module can be plugged into different BaseUnits with different connection wirings. The information that is required for the installer, namely to which connection point a signal is assigned, arises through the combination of the two items.

Note:

In order for the BaseUnits to be exchanged with TIA Portal, they must be designed as accessories of the electronic modules.

Example of a configuration with fail-safe I/O modules

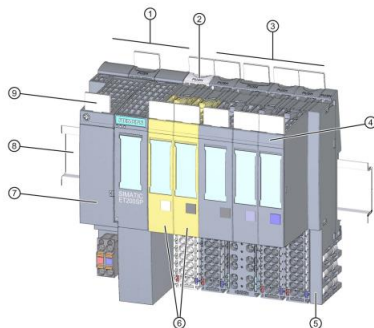

- ① Interface module
- ② Light-colored BaseUnitBU..D with infeed of supply voltage
- ③ Dark-colored BaseUnitsBU..B for conducting the potential group further
- ④ I/O module
- ⑤ Server module (ships with the interface module)
- ⑥ Fail-safe I/O modules
- ⑦ BusAdapter
- ⑧ Mounting rail
- ⑨ Reference identification label

Figure 2-4 Example of a configuration of the ET 200SP with fail-safe I/O modules

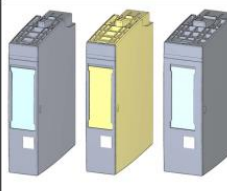
BaseUnit	<p>The BaseUnits provide the electrical and mechanical connection of the ET 200SP modules. Insert the I/O modules onto the BaseUnits.</p> <p>Suitable BaseUnits are available in each case for the different requirements (see Selecting a suitable BaseUnit (Page 26))</p>	
I/O module / fail-safe I/O module	<p>The I/O module determines the function at the terminals. The controller detects the current process state via the connected sensors and actuators, and triggers the corresponding reactions. I/O modules are divided into the following module types:</p> <ul style="list-style-type: none"> • Digital input (DI, F-DI) • Digital output (DO, F-DO) • Analog input (AI, F-AI) • Analog output (AO) • Technology module (TM) • Communication module (CM) 	

Parts management

BaseUnit

Each BaseUnit is created as component in the PLC product group and is identified as an accessory. The accessory part contains the function templates:

1. For a PLC box
2. For all the PLC connection points that do not come from the electronic module (power supplies of the PLC card, auxiliary connection points, etc.)
3. These connection points have connection point designations.
4. No channel is entered at the connection points because it depends on the electronic module.

Designate each BaseUnit on the **Accessories** tab as an accessory by activating the corresponding check box.

Electronic module

Each electronic module is created as an individual component in the PLC product group. The part contains the following as function templates:

1. The PLC box
2. All the PLC inputs and outputs, not however the connection points of the BaseUnit (for example power supplies of the PLC card, auxiliary connection points, etc.)
3. The channel is entered at the connection points
4. No connection point designation is entered at the connection points because it depends on the BaseUnit used.

All the BaseUnits that can be used with the electronic module are assigned as optional accessories to the module. This simplifies the accessory selection later on because only those BaseUnits are offered for selection that are suitable for the electronic module.

Example of an accessories listing for the module 6ES7131-6BF00-0BA0

Row	Part number / name	Variant	Record type
1	SIE.BU15-P16+A0+12B/T	1	Component
2	SIE.BU15-P16+A0+12D/T	1	Component
3	SIE.BU15-P16+A0+2B	1	Component
4	SIE.BU15-P16+A0+2B/T	1	Component
5	SIE.BU15-P16+A0+2D	1	Component
6	SIE.BU15-P16+A0+2D/T	1	Component
7	SIE.BU20-P12+A0+0B	1	Component
8	SIE.BU20-P12+A0+4B	1	Component

The **PLC type designation** is to be entered on the **PLC data** tab for the PLC data exchange.

Macros

A macro with the variants for each combination with BaseUnits is stored at the electronics module (optionally per channel with placeholder objects).

The assignment channel to connection point is made in the macros.

Enter the underlying **Macro** on the **Technical data** tab in the parts management.

Configuration

The electronic module and BaseUnit has the same device tag in the schematic.

The BaseUnit is assigned to the electronic module as an additional part. A device selection is also possible.

PLC data exchange

BaseUnits are taken into consideration during a PLC data exchange in AutomationML format if they

1. are stored in the parts management with a PLC type designation and
2. are specified as an additional part number at the electronic module.

No additional parts are transferred at a PLC data exchange via other formats. After an import the used BaseUnits are therefore to be selected as accessories, if applicable.

Special case with separate DT for BaseUnit and electronic module

The BaseUnit establishes the connection between the electronic module and the sensor, actuator, etc. To this purpose PLC connection points with 2 connection points are used. For this case EPLAN makes the new function definition "PLC connection point, 2 connection points" available that is used for a through line.

Function templates of the type "PLC connection point, 2 connection points" are entered at the parts of the BaseUnits. In addition macros, analog to the electronic modules, for each combination with electronic modules. (Optionally per channel with placeholder objects.)

The assignment channel to connection point is made in the macros.

If the user has selected a macro for the BaseUnit or electronic unit channel-wise, they can select the respectively other macro on the basis of channel or connection point designation.

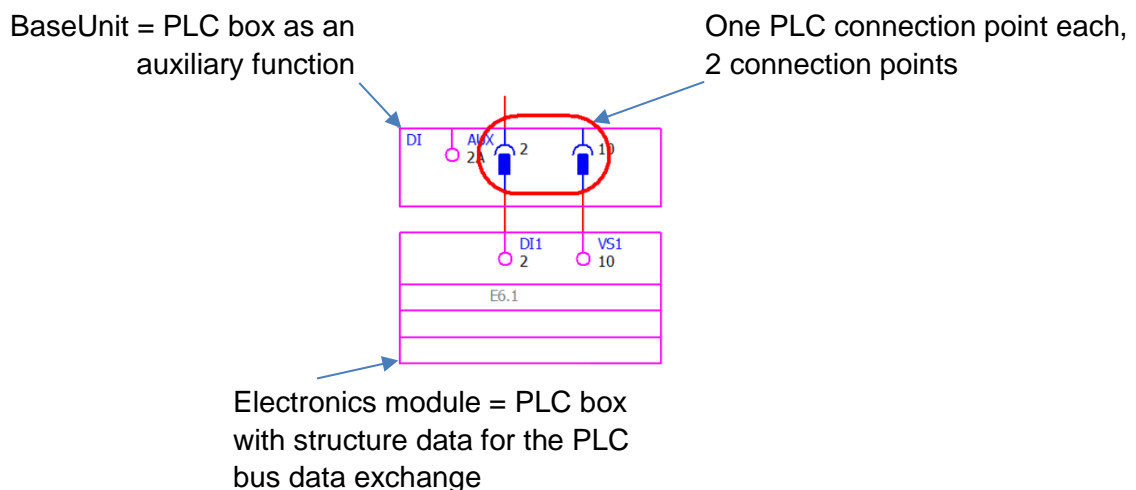

The PLC box of the BaseUnit is used as an auxiliary function.

If the PLC box of the BaseUnit has an own DT, the structure data at the main function of this PLC box is *not* filled.

PLC connection points with the function definition "PLC connection point, 2 connection points"

1. Can have a channel information.
2. Are displayed grouped in the PLC navigator in the channel-oriented view.
3. Can be filtered.
4. Are not addressed.
5. Are not taken into consideration during the output of an assignment list.
6. Are not exchanged during a PLC data exchange.
7. Are not taken into consideration during PLC target tracking.